

Structural Evaluation and Retrofitting of Roofed Fountains at the Center of Open Courtyard of Historical Islamic Religious Buildings in Cairo.

Yaser Yehya Amin Abdel-Aty

Associate Professor, Conservation Department, Faculty of Archaeology,
Cairo University, Egypt

Abstract

The present paper studies structural stability, seismic vulnerability and retrofitting proposals of the roofed fountains that are located at the central open courtyard of historical Islamic religious buildings in Cairo. Although, these fountains are considered among the major interior architectural elements that can be found at numerous historical buildings in Cairo through all Islamic eras, besides their vital functions and protrusion; they have not been covered sufficiently by researchers. Architectural design of these historical fountains is generally similar, which makes them sharing nearly the same major structural deficiencies and risks; such as losing its timber domed roof and sometimes they totally collapse. The general structural system of these fountains is characterized by slender stone columns, high ductility, poor connections. On top of that, it lacks any bracing system. The structural stability and overall dynamic behaviour of these historical central fountains in Cairo are checked out through eigen-value and response spectrum analyses of a number of 3D finite element (FE) models of a representative case-study, which is the central fountain of "Sultan Hassan" madrasa (1356-63 A.D.). Evaluation of results of different models that represent a number of retrofitting alternatives would help to derive conclusions and recommendation for fountain's structural conservation and retrofitting.

- **Keywords:** Fountain, masonry, drift, vulnerability, bracing, seismic retrofitting, strengthening.

1. Research Aim

The present research aims to study analytically the structural stability of central roofed fountains at historical Islamic religious buildings in Cairo under permanent and seismic loads, using numerical modelling techniques of computer software that applies Finite Element Method (F.E.M.). This would help to establish various alternatives for retrofitting these historical fountains against high ductility and lack of efficient bracing system in their buildings. Although the proposals provided may not fully satisfy all conservation principles and requirements, however they are almost reversible; they would enhance the structural stability and seismic strength of the fountains, and they would minimize the lateral drift of the fountains under seismic loads, which is the main cause of damages in their main elements and collateral brittle building materials; such as claddings and plasters.

2. Introduction

The central fountain is one of the major interior architectural elements that can be found at numerous historical Islamic religious buildings in Cairo; mosques, madrasa (theological schools), dwellings, palaces, etc., through all Islamic eras. It is generally located at the centre of the main open-courtyard of its building (El-Basha 161). Originally, it poured water into its basin and jet it into the air to fall down back into the basin. It sometimes provided water for drinking and washing of visitors of its building. It also added soft and humid atmosphere as well as decorative and dramatic effects to the courtyard, which was a symbol of luxury. Thus, it helped to cool-up the prevailing hot weather of its surroundings during summer. Besides, spraying water through the air helped to purify water for ablution (Waziri, 189).

At historic Cairo, fountain's pool was generally built in a polygonal shape, most likely octagonal, and it was surmounted by a roof that followed its basin shape; see Fig.1. Area and height of the roof of the fountain was usually proportioned to its surrounding area of the open courtyard. The roof was built as either a flat or a domed shed that rested on eight marble columns. Function of the roof was to keep water cold and clear, since hot weather is always prevailed most of months through the year in Cairo. Sometimes small fountains were built in a hexagonal shape that supported on six columns only (Mahir, S. 97).



Fig. 1: Examples of central fountains at historical Islamic religious buildings in Cairo: **a)** “*A’mr ibn al-’As*” mosque (641 AD), **b)** “*Sultan Hassan*” madrasa (1356-63 AD), **c)** “*Sultan Barquq*” mosque (1384-86 AD) and **d)** “*al-Mo’aid Sheikh*” mosque (1415-20 AD).

The structural system of fountains’ superstructure is generally very vulnerable to failure by seismic actions. It is usually characterized by high ductility, lack of any bracing system, slender marble columns and poor connections and joints; either between column’s body and its stone base and head or among other timber elements. Past observations of central fountains at numerous historical religious buildings in Cairo during the last decades had revealed that its roof was always liable to failure and destruction by moderate to severe Earthquakes (Comite’ de conservation). In some cases, full destruction of the entire fountain’s superstructure occurred; in such as “*al-Merdani*” mosque (1338 A.D.); see Fig. 2: -a, -b. Other fountains were found as only roofless basin; such as at mosque of “*Shaykhu*” (1349 A.D.); see Fig. 2-c. Also, fountain of “*Sarghatmash*” madrasa (1356 A.D.) had lost its dome in the past Century and was late restored by rebuilding its dome; see Fig. 2: -d, -e.

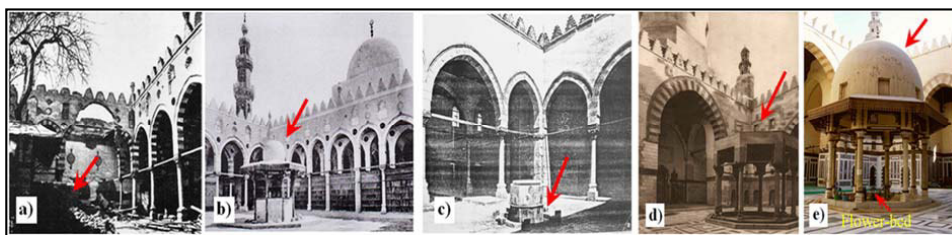

Fig. 2: Past structural damages and failures of a number of fountains’ roofs at historical Cairo: **a), b)** “*al-Merdani*” mosque: 1338 AD before and after restoration, **c)** “*Shaykhu*” mosque: 1349 AD (a, b and c after: *Comite’ de conservation des monument de l’art Arabe*), **d) and e)** “*Sarghatmash*” madrasa 1356 AD before (Ibrahim 455) and after restoration.

Many of historical fountains’ roofs were constructed of light building materials, through building them of timber and mortar. Their weak connections and joints, besides slender columns, had caused fountains’ sheds to experience high lateral drift under seismic loads. During moderate to strong earthquakes, wide displacement, tensile stresses and vulnerable connections may cause many fountains to lose their roofs or at least can cause high deterioration and damages at collateral brittle building materials (i.e. claddings and plaster).

This paper reports an analytical study about structural stability and proposals for retrofitting of the central fountain of the “*Sultan Hassan*” madrasa, which was built in 1363 A.D. (764 A.H.) during the “*Bahri- Mamluk*” era; since it represents a good example of fountain’s architecture of abundant religious Islamic buildings

at historic Cairo. It is considered the hugest of all historical fountains in Cairo (Al-Maqrizi 520); see Fig. 1-b. More details about history of the madrasa are covered in many references, such as (Abouseif), (Yeomans), (Mubark) and (Abdel-Wahab). It also suffered from several deterioration and destruction along its long history. Without many restoration efforts in the past, it may be demolished as many fountains that they do not exist nowadays. This paper outlines the main causes of failures in this fountain's superstructure and provides proposals for its structural retrofitting against seismic loads, which are considered the major risks that threatens most of historical buildings in Egypt. In order to better understand the global dynamic behaviour of the fountain's roof during the past earthquake actions, preliminary dynamic analysis; applying eigenvalue and response spectrum analyses, have been performed. The 3D finite element (FE) models are developed with a well known computer package that is utilized in the field of structural engineering. After a careful diagnosis and evaluation of the safety of the fountain in its current state, suggestions are provided for retrofitting its structure to reduce seismic vulnerability based on results of the implemented finite element models. Recommendations can help to preserve other similar central fountains at other historical buildings in Cairo, since such proposals have not yet applied to any historical buildings in Egypt or other Arab countries.

3. Architectural description and documentation of the central fountain of "Sultan Hassan" madrasa

The researcher conducted up-to-date photographic documentation in addition to architectural CAD-drawings of the current condition of the central fountain of the "Sultan Hassan" madrasa (Fig. 3, 4, 5). The central fountain consists of an octagonal stone-basin surmounted by a wooden domed roof, which takes the form of elevated open-room that rests on eight marble columns (Fig. 3). This room is composed of octagonal brick-masonry walls with stucco-grill windows through, which is surmounted by a wooden dome. The dome and walls are covered with plain lime-plaster from both outside and inside surfaces. The wooden dome is composed of doubled interlace domes. The outer dome had onion shaped while the inner had a circular shape (Fig. 4-a). The doubled-dome of the fountains rests over a timber ring beam, which is carried by a number of wooden corbels. These corbels are covered by timber boards of thickness 3 cm from top and bottom sides, where exposed surface is ornamented with wooden veneer (Fig. 3-b). The corbels are fixed at timber edge-beams that are embedded through the octagonal brick-masonry walls at the top of the fountain (Fig. 4: -c, -d).

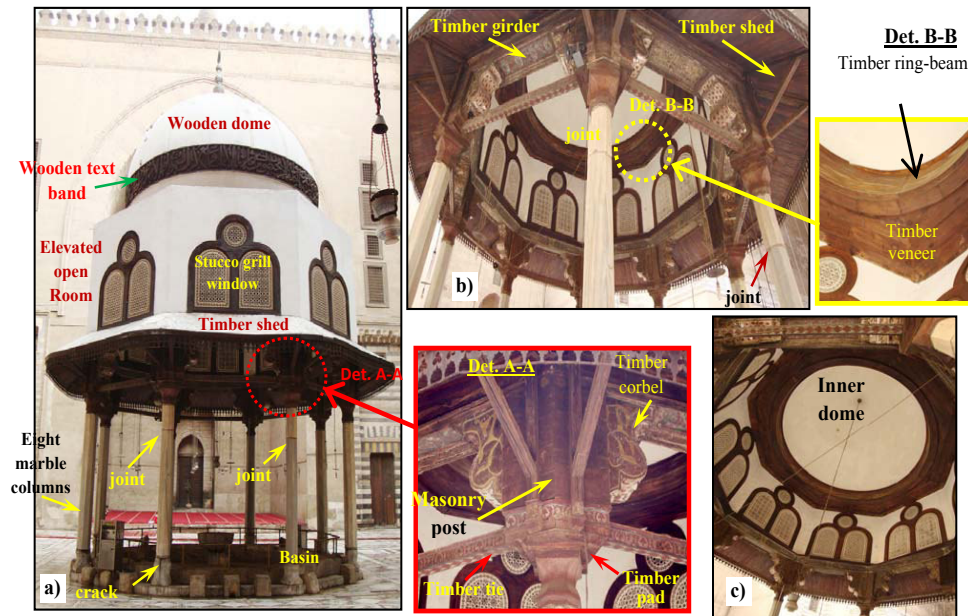

Fig. 3: Photographic documentation of the current condition of the fountain (by the researcher): **a)** one façade looking towards West, **b)** major timber structural elements, **c)** view from inside (looking up).

The entire timber roof rests upon eight brick-masonry posts, which in turn support over timber-pads that are built-up of successive timber boards of 3 cm thickness and bonded together with natural glue (Det. A-A at Fig. 3). Each brick post, through its timber pad; rests over an octagonal marble column through its bell-shape head. A continuous protruded shed is extended through all periphery of the base of the elevated room (Fig. 4-c). It is supported by timber posts, which are fixed on the brick posts. Each of the fountain's eight octagonal columns is made of one solid body of white marble; of diameter = 0.4 m. Only two columns (No. 5 and No. 6 in Fig. 4-b) have diameter = 0.35 m, which their marble bodies are not made of one part like the others (Fig. 3-b). It seems that those two columns were broken in the past, and restoration work in 19th Century (It is covered in the following section) had substituted them with two shorter columns of lesser diameter than the previous. Each of them was elongated to the required height with a marble extension at upper part. Columns have bell-shaped crowns and bases that are made of marble (Fig. 5).

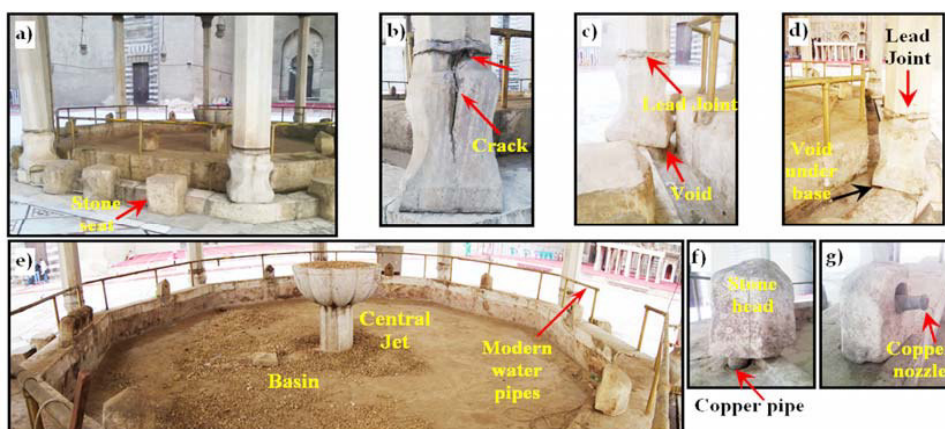

Fig. 5: Details of columns' stone-base and the basin of the fountain: **a)** main stone (strip) footing of the fountain with octagonal shape, **b)** marble column's base cracked vertically, **c)** and **d)** column's base are partially hanging, **e)**, **f)** and **g)** details of fountain basin and water-jets.

4. Structural Deficiencies and Deterioration and Past Restoration Work of the Fountain

Throughout history, Egypt has been and still is prone to moderate as well as strong earthquakes. Past earthquakes that occurred in Egypt were compiled from Arabic documents and earlier earthquake catalogues. About '83' earthquakes were recorded during the period from 2200 B.C. to 1899 A.D. The reported earthquakes reached their highest number (seventeen) in the 19th Century. The strongest earthquakes reported were in the years 1847 and 1870, which caused strong damages to buildings and lives (Badawy 132). Hence, the madrasa of "Sultan Hassan", including its main central fountain, had suffered many severe structural deficiencies and deterioration along their lifetime and especially during that period. Consequently, many restoration works were conducted to numerous parts of the madrasa during the past era, among which is the major project achieved by engineer 'Max Herz' Pasha during the 19th Century (Waly 12). This project restored the fountain's structure and retrieved its windows to their original shape (Fig. 6). Additionally, it removed the neighboring ablution, which was later reconstructed at the center of the courtyard of "al-Merdani" mosque (Fig. 2-b). The project restored and renovated various elements of the mosque (e.g. minarets, mausoleum's dome, walls, marble claddings above walls and floor, stucco carvings, etc.) to their present shape (István 57), of which details are out-of-scope of the present research. The researcher analyzed the previous documents and photos of the fountain and found the major deterioration and deficiencies that occurred during the past centuries. These are as follows (Fig. 6):

- Most of the outer timber dome's elements had severely deteriorated. This is detected in the cracks and losses in lime surface plaster. Timber veneers have also faced deterioration.
- Timber-shed had lost its surface veneers and several of its timber logs inside.
- Lime-plaster over surfaces of brick-masonry walls had deteriorated, and wooden grills of windows were highly deteriorated and broken.
- There is a slight tilt in a number of marble columns with vertical cracks, of 5 - 10 mm wide, at their bases.
- Two columns at S-W side (No. 5 and No. 6 in Fig. 4-b) had joints at their tops (near the columns' heads), indicating that they were broken and restored by the restoration project of "Herz Pasha".

During the last decades, the fountain had suffered many other deficiencies and deterioration due to various causes. The most dangerous of which was the 12th October 1992 earthquake in Cairo that was followed by a number of other tremors during the following years.

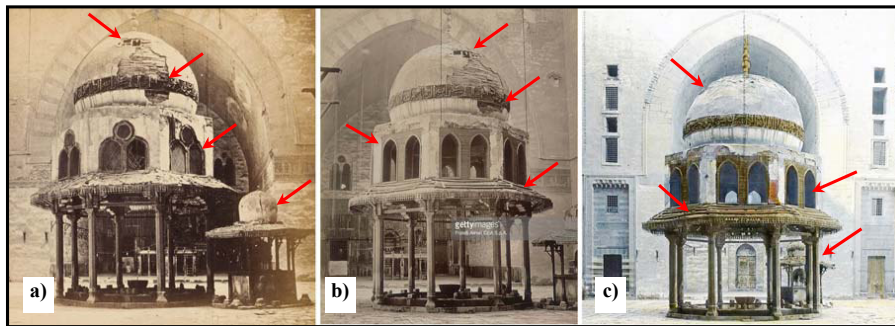

Fig. 6: Fountain's past deteriorated condition from 1862 to 1900 A.D.: **a)** old photo in 1862 looking towards the South, shows original windows and the ablution (after: Bedford), **b)** old photo in 1900 from the same side, shows windows after the alternation to a new incompatible shape (after: Alinari), **c)** another old photo in 1900 looking towards West, by Herz Pasha, before his major restoration project (after: Herz).

5. Methodology and Materials of the Present Research

In order to better understand the major static and dynamic behaviour of the fountain's superstructure, under possible cases of loading, 3D-finite element (FE) models are developed with SAP2000 v.16 software (CSI Analysis Reference) that represent the current condition and the various retrofitting proposals of the fountain's superstructure. To implement the global FE models, the geometry of the fountain has been discretized using: (i) frame element to represent: timber corbels, timber girders, timber ties, and the eight marble columns, (ii) shell element to represent timber composite dome and

brick-masonry walls. The meshing of the model has been adapted in order to respect the geometric characteristics of the fountain, following the dimensions in Fig. 4.

Various views of the main numerical model (model-1) are shown in Fig. 7. Each alternative of structural retrofitting proposals is represented in a separate 3D-model that is derived from the original one (model-1). All models are analysed under both static and dynamic load cases. Static case covers the permanent loads including self-weight, while seismic action has been introduced through the eigenvalue analysis (for modal natural frequencies and fundamental participation factors) and linear response spectrum analysis. All considered loads follow the Egyptian Code for calculating loads (ECP-201). Response spectrum is considered according to article (8-4-2) in 'ECL' which provides maximum spectral acceleration: $S_0(T) = 2.5 \text{ m/sec}^2$ (ECP-201 115); as reported in Fig. 7-e. For the identification of the spectrum, the following parameters have been used: soil type 'D' since very weak soil is expected (i.e. landfill); and the maximum expected peak ground acceleration (PGA) = 0.15g for zone 'III' in Egypt, which Cairo lies inside (ECP-201 155). **Working** stress design method in accordance to the Egyptian code of masonry buildings (ECP-204) will be implemented to structural evaluation of the models' results. According to 'ECP-201', forces and reactions, resulted from response-spectrum load case are in ultimate values and should be divided by (1.4) to convert them to working stress value (ECP-201 107). Lateral building sway is checked for all models using total drift ratio, which is defined as the lateral displacement at the top-most occupied floor of the structure (D); divided by the height from grade to the uppermost floor (H). Unfortunately, Egyptian code for masonry does not specify limits to lateral drift under lateral loads. A number of foreign building codes provide different values of this parameter limitation to check. One provides range (Griffis 7) of maximum allowable total building drift (D_{all}) = $H/100$ to $H/600$. The Indian code (IS-1893 27) recommends storey drift in any storey, due to the minimum specified design lateral force with partial load factor of 1.0, not to exceed 0.004 times the storey height. The research will implement $H/400$ as the limit for the lateral drift under seismic loads, which is presented in response spectrum load case.

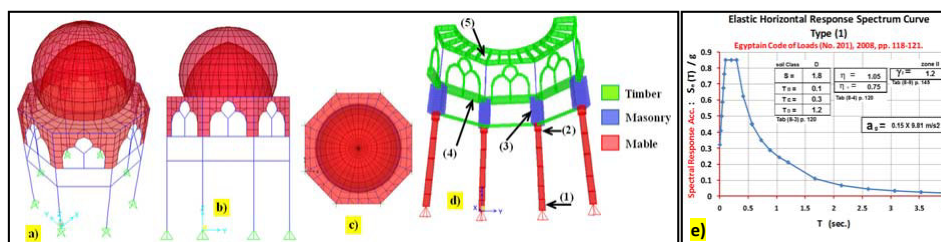

Fig. 7: Details of the 3D-numerical model and response spectrum curve: **a)** perspective top-view, **b)** elevation, **c)** plan, **d)** extruded half-perspective view showing main frame elements, its materials and critical sections for structural analysis' results and **e)** Response Spectrum curve according to 'ECP-201'.

Visual and microscopic examination of micro samples of all structural elements have shown that the main building materials of the fountain building are: white marble similar to Carrara type for the eight columns, brick masonry work for walls and pillars, limestone for footings and basin, and 'pine' wood for roofs' girders, joists and domes. The following properties in Table 1 were considered in structural analysis and evaluation works of all studied models in the present research, based on previous researches (Wood Handbook 5-7), (Mahir et al. 41), (Ciccu et al. 81), (Cadoni et al. 2) and (Abdel-Aty 231).

Table 1: Mechanical properties and allowable **working** stresses of historical building materials considered in the structural analysis and evaluation of "Sultan Hassan" fountain.

Material type and Symbol	Bulk density r kN/m ³	Comp. stress f_c (N/mm ²)	Tensile stress f_t (N/mm ²)	Flexure Stress		Shear stress q (N/mm ²)	Elasticity modulus E (N/mm ²)	Poisson's ratio n
				(Comp.) f_{cb} (N/mm ²)	(Tensile) f_{tb} (N/mm ²)			
Timber (T)	5	7	6	8	9	0.8	1000	0.30
Marble (M)	27	6.7	0.1	3.8	1	0.5	4900	0.26
Limestone (S)	22	3.5	--	3	0.10	0.20	2000	0.22
Brickmasonry (B)	18	2.2	--	1.8	--	0.10	1000	0.25

6. Structural Analysis and Evaluation of the Present State of the Fountain's Superstructure (Model-1)

The first 3D numerical model (model-1), shown in Fig. 7, studies the present structural state of the fountain (original case), to check its stability and safety levels. The most critical sections of different structural elements of the fountain and its locations are shown in Fig. 7-d. Under static service loads, the following results are found (Fig. 8): maximum axial compression force in marble columns is: (N) = -85.6 kN that causes maximum normal compressive stress: (f_N) = -0.69 MPa. It is safe according to values in Table 1. The principal normal stresses of various timber frame elements are shown in Fig. 8-b, which maximum value = 3.54 MPa that is located at the fixed end of main timber corbels. Principal tensile stresses' contours of shell-elements are shown in Fig. 8-c. Values of other critical sections of the model-1 are provided in Table 2. They all prove to be structurally safe when compared with reference values in Table 1. These results agree with the stable current condition of the fountain, due to light weight building materials of its superstructure. Slenderness ratio of marble columns is (1) = $4.9 / 0.4 = 12.25$, which is risky for natural stone columns (ECP-204 47). This ratio

is calculated without considering any modification factor to the final conditions of the columns, which may increase this value more, as they can be considered unconfined. Thus, columns can be classified as slender and liable to buckling failure or rocking motion by seismic loads. The latter, in critical cases, could lead either to overturning of the column or to local material crushing due to the stress concentration in its bottom edge. On this basis, it is clear that the effect of ground shaking could be more critical and dangerous to columns which are already cracked due to different environmental and deterioration reasons. Moreover, the brittle nature of marble and its low tensile strength can lead to quick propagation of micro-cracks in the column's body, which can seriously damage it.

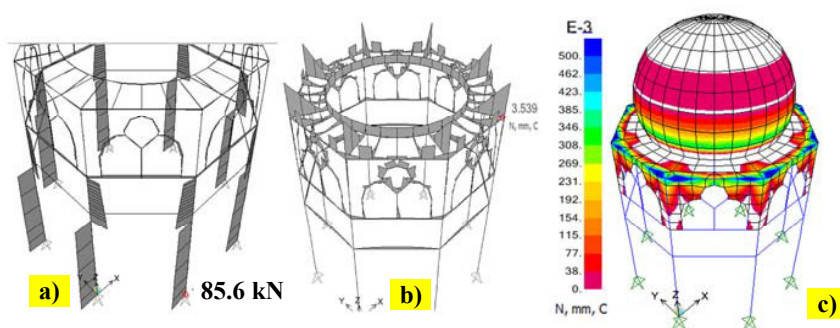

Fig. 8: Main results of the 3D-model of the original case (model-1) under permanent loads only: **a)** normal force diagram, **b)** principal stresses in frame-elements (N/mm^2) and **c)** principal tensile stresses in shell-elements under permanent loads only (N/mm^2)

To better understand the global dynamic behaviour of the fountain and to investigate its damages during the previous years, which were not reached in the analysis under static load case, a preliminary dynamic analysis is conducted, applying eigenvalue and linear response spectrum analyses. Eigenvalue analysis shows high modal participating periods: first modal period is (T_1) = 3.56 sec. The main Eigen modal shapes and its relevant periods, types and mass participation ratios are shown in Fig. 9. Linear response spectrum load results in high total lateral drift of the fountain in x-direction (D_x) = 6.9 cm (Fig. 11-a). It also induces additional high bending moments at the top end of marble columns that cause high tensile normal stresses ($f_{t,w}$) = (1.96/1.4) = 1.4 N/mm^2 (Fig.11-b). This value is **unsafe** according to Table 1. If we consider the allowable drift = $H/400$, and the total height of the fountain is 14.9 m, then the allowed drift value = 3.7 cm. Consequently, the resulted total drift value under response spectrum case will be also **unsafe** by 186%. This may cause, with the high slenderness ratio of columns, a buckling failure and a rise in bending stresses due to P-delta effect. Hence, the eight marble columns are found to be the most vulnerable structural elements of the fountain under seismic actions, since the highest tensile stresses are located at

their heads; where lead connection between columns' bodies and their heads lies. The timber pads that lie between the columns' head and masonry posts are also considered other weak joints. These connections depend on glue and bearing only, which are not robust enough to resist bending stresses induced by seismic loads.

The general conclusion of this analysis is that the structure of the fountain is safe under merely static loads. However, it is unsafe under seismic loads as they may cause excessive total drift that is considered unsafe. They may also cause damages and deterioration to claddings, brick masonry walls, plaster, timber dome, stucco window grills and other collateral non-structural materials, which have already taken place in the past eras. Thus, the fountain should be provided with a bracing system to increase its lateral stiffness and reduce its total drift under expected seismic loads. Moreover, the unsafe sections at the top end of marble columns, where lead joints are connected between the columns' bodies and their heads, should also be retrofitted to resist the resulting stresses from both seismic loads and the installation of bracing system that is expected to raise the stresses due to the increase in overall stiffness of the structure.

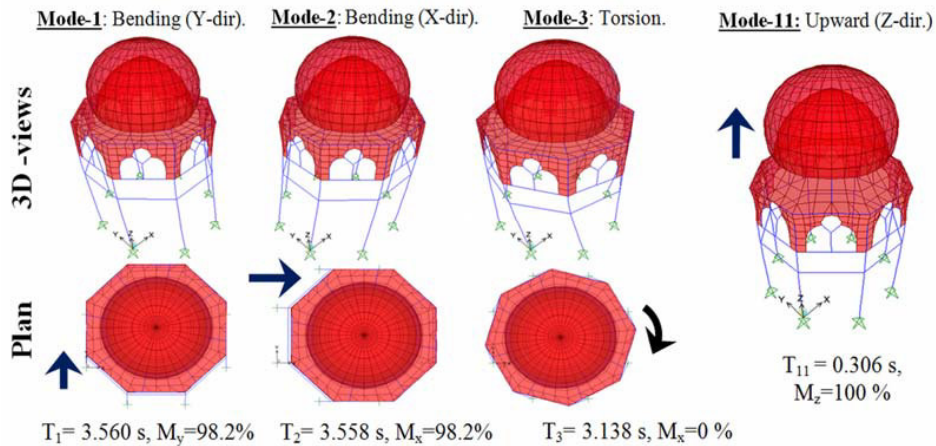

Fig. 9: The major eigen modal shapes, periods (sec.) and mass participation ratios of the original case (model-1): bending mode in N-S, bending mode in E-W, torsion mode, and upward.

7. Structural Evaluation of a Number of Retrofitting Proposals for the Fountain's Superstructure

A number of structural retrofitting proposals for the fountain to enhance its seismic behaviour and stability, and to minimize the lateral drift are provided and evaluated in this section. Each proposal is introduced in a separate numerical FE model, which is derived from the original model (model-1), by adding the proposed retrofitting to it. All proposals would install a bracing system and strengthen marble columns through the

application of steel collars over bottom and top joints between the body and column's stone head and base. Steel collars restrain relative sliding between the column's base and head, limit columns' amplitude of oscillations, and they are able to reduce risks of columns overturning and rocking (Marinella et al. 347). Each collar will be concealed by covering it with aesthetic brass ring.

Table 2: Results of structural analysis work of fountain's original model (model-1): showing internal forces and moments at most critical sections of Fig. 7-d and its resulting stresses.

Critical section	Material symbol	Normal force	Shear force	Bending moment	Max. principal normal stress	Safe or Not	Max. shear stress	Safe or Not
ID		(kN)	(kN)	(kN . m)	(N/mm ²)		(N/mm ²)	
1	M	-86.0	0.1	0.0	-0.69	Safe	1.06 E-3	Safe
2	M	-75.0	0.1	0.5	-0.64	Safe	1.09 E-3	Safe
3	B	-69.0	0.1	0.4	-0.102	Safe	0	Safe
4	T	9.0	8.0	4.0	0.49	Safe	0.14	Safe
5	T	-2.2	7.0	-9.4	3.6	Safe	0.24	Safe

Negative signs (-) for compression, while positive for tension

7.1. First Retrofitting Proposal: Increasing the Columns' Diameter Only (Model-2):

This alternative requires simply to increase the marble columns' diameters to be = 0.7 m, in order to reduce their slenderness ratio to value = 7 and to reduce tensile stresses resulting from seismic forces. This can be achieved by covering the entire face of every side of the octagonal columns with compatible marble clad plate in one piece of the same type of the original marble and with thickness = 13 cm to achieve the overall diameter. This operation can be preceded by wrapping the original columns' body with CFRP (carbon fibre reinforced polymer) laminates, using compatible epoxy and following scheme in Fig. 12-a. The laminates width equals 0.2m, spaced by 0.6m apart, and winded for three turns to achieve sufficient overlap. This wrapping aims to confine and reinforce the columns' vulnerable bodies with regard to micro-cracks and to increase their carrying capacity under vertical loads. Eigen value analysis for model-2 shows high modal participating periods, which are nearly similar to the ones of the original case (e.g. first modal period: $T_1 = 3.224$ sec.) (see Fig. 11-a). Linear response spectrum load case results in higher total lateral drift of the fountain than the original case (d_x) = 7.3 cm (Fig. 11-b). The resulted tensile normal stresses at the top end of columns have considerably decreased by 64% compared to the original case (Fig. 12-b). This proposal merely increases the columns' safety against both buckling and seismic loads, while it leaves the high lateral drift problem unsolved.

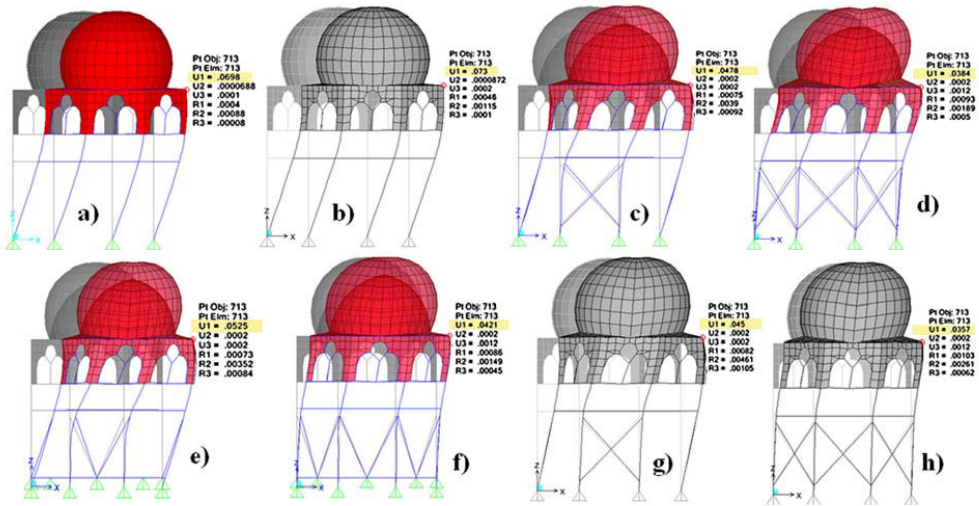

Fig. 10: Comparison of all models' lateral drift between original case and different retrofitting proposals under response spectrum load case in meter: **a)** original case, **b)** increase columns' diameter to 70 cm, **c)** install '4' X-bracing, **d)** install '8' X-bracing, **e)** install '4' V-bracing, **f)** install '8' V-bracing, **g)** install '4' X-brac. + col. diam. 60 cm; and **h)** install '8' X-brac. + col. diam. 60 cm.

7.2. Second Retrofitting Proposal: Installing 4 x-bracing System Only to the Original Condition without Any Other Modifications (Model-3):

This proposal requires merely installing four mutual x-bracing systems among the fountain's marble columns, following the scheme in Fig. 12-e, but without any strengthening work for other structural elements or the columns' increasing diameter. This retrofitting technique may be considered innovative for historical buildings in Egypt, since it was not applied before as a permanent solution. The x-bracing system is composed of two high strength stainless-steel tie-bars, of 25mm in diameter, forming together the x-shape. The bars are welded at its intersection point. Each tie-bar would be bolted in octagonal stainless-steel collars (Fig. 12-c) that are mounted above lead joints at the top and bottom of every marble column. The bolted connection between tie and collar would allow tie to rotate, which satisfies link-member state. Also, tight collars are aimed to confine columns at their most critical sections; thus, enhancing their seismic resistance.

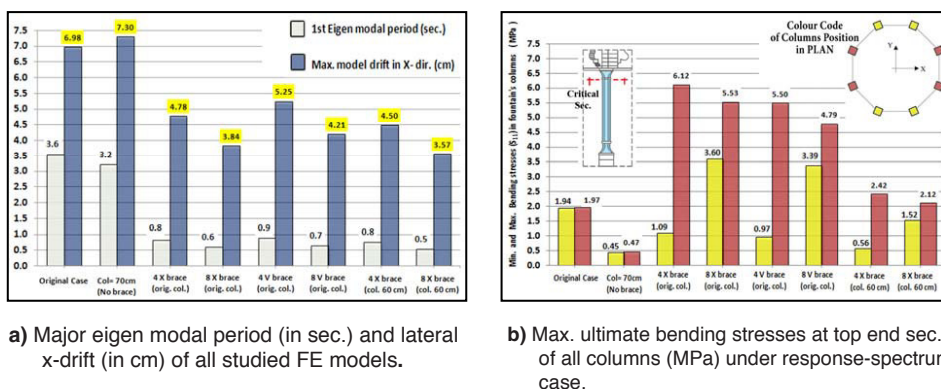

Fig. 11: Comparison among results of all F.E. models that represent original and retrofitting cases.

Although the possible objection of x-bars is from visibility point-of-view, it is considered easy, feasible, fully reversible since it can be easily and totally dismantled, and an efficient retrofitting compared to other proposals that provide low tensile stresses and lateral drift under response spectrum. The visibility could be accepted owing to the small thickness of bars that will be painted in mat black colour. Compared to the vast area of the courtyard and the fountain's large size, it would conceal the bars, and the attained seismic resistance enhancement. Moreover, it is considered an efficient permanent shoring system or temporary structural retrofitting until another efficient system is created. Results of eigen value analysis for model-3 shows considerable reduction in modal participating periods (e.g. first modal period: $T_1 = 0.82$ sec. that is 77% less than original case). This proves enhancement in the overall structural stiffness of the building. Also, response spectrum load case results in a lower value of the total lateral drift of the fountain than the original case, as (D_x) = 4.8 cm (Fig. 10-c, 11-a). The resulted tensile normal stresses at the top columns' end have decreased by 56% than the original case (model-1) for the four columns in the opposite direction to seismic load, while they have increased by 315% for the rest of the four columns that lie along load direction (Fig. 11-b). To overcome the high tensile stresses, upper lead joints between the column's body and head should be wrapped with CFRP laminates of 4 cm wide using proper epoxy, before mounting steel collar above it. The laminates would be winded for three turns to achieve sufficient overlap. Maximum working tensile stresses in steel tie-bars is 106 N/mm², which is 53% of the allowed value for high tensile steel used. In fact, this proposal reduces the columns' stresses and total drift under seismic loads considerably and satisfies reversibility. Also, leaving four bays open can help to show the fountain's original view. Yet, lateral drift and the columns' buckling criteria are still unsafe.

7.3. Third Retrofitting Proposal: Installing 8 x-bracing Only to the Original Condition without Any Other Modifications (Model-4):

This retrofitting alternative is similar to the previous proposal, but with the installation of eight x-bracings (i.e. between all columns). Enhancement in seismic stability is obtained as follows: Eigen value analysis provided less periods ($T_1 = 0.602$ sec.). Response spectrum load case resulted in total drift (D_x) = 3.8 cm (Fig. 10-d, 11-a), which is almost safe (the allowed value ($H/400$) = 3.7 cm). Maximum tensile normal stress at the column's top section = 3.6 MPa for the four columns in the opposite direction to seismic load and it is = 5.53 MPa for the rest, which are both unsafe. They are 185% and 285% respectively more than the original case. This alternative overcomes the drift problem, while buckling and high tensile stresses at the columns' heads are still unsolved. As in the previous alternative, wrapping CFRP laminates under each steel collar can resist the high local stresses. In fact, this retrofitting proposal in comparison to the '4' x-bracing system provides more seismic stability but it is more expensive, and its visibility is sensed more.

7.4. Trying v-shape in Place of x-bracing System (Model-5 and Model-6):

The researcher repeated the last two bracing proposals, only he substituted x-system with v-system. Response spectrum analysis shows nearly similar results in lateral drift and tensile stresses at the columns' top sections (i.e. only 8~9% increase in comparative values of drift while 8% decrease in stress values) (see Figures: 10-e, 10-f and 11). Eigen value analysis shows almost similar results (only 8% increase in eigen period values). Hence, the researcher prefers x-shape, since welding tie-bars at intersection points would shorten its unsupported length than in v-bracing case. However, neither of them has less visibility.

7.5. Trying x-bracing Systems by Increasing the Columns' Diameter (Model-7 and Model-8):

To conclude these structural studies, the researcher examined the two previous proposals of installing x-bracing system (either four or eight systems) by increasing the diameter of all marble columns to be 0.6 m, which makes the columns' slenderness ratio = 8.17 (it is 53% less than the original case). This aims to benefit from the bracing system by reducing the lateral drift under seismic action, as well as overcoming the high tensile stresses and slenderness of the marble columns of the two previous proposals (model-4 and model-5). The full details of this retrofitting proposal are illustrated in Fig. 12. Also, columns would be wrapped by CFRP strips, following the scheme in Fig. 12-a. Each face of the octagonal marble columns would be covered with 8 cm marble plate of compatible marble type over the full surface of each side as one piece and using suitable cementing mortar. Then, stainless steel collars would be mounted and tightened over the top and bottom of lead joints. Finally, x-bracing steel bars would

be bolted into the holes of collars and each pair would be welded at the intersecting point. Comparing results, the final two proposals provide great enhancement in column buckling, lateral drift and seismic stability. The best result is obtained in model-8. Eigen value analysis shows periods of 10% less than the previous relevant proposals of models #3 and #4 (Fig. 11-a). Response spectrum load case shows total drift values 8% less than the previous relevant proposals. Maximum tensile normal stresses at the upper columns have reduced by about 35 ~ 40 % compared to models #3 and #4 (Fig. 11-b). Last model (#8) provides nearly similar stress values as the original case (model-1) for the main four columns in x-direction and 75% of stress values of the original case for the remaining four columns.

From the structural point of view, the last proposal (model-8) provides the best results of all studied retrofitting alternatives and overcomes all structural problems. The researcher prefers model-7 (four x-bracing with increasing columns' diameters) since its analysis' results are rather close to the ones of model-8, while its visibility, intervention criteria and overall costs of the 'four' x-bracing system is preferable and less than the 'eight' x-bracing system.

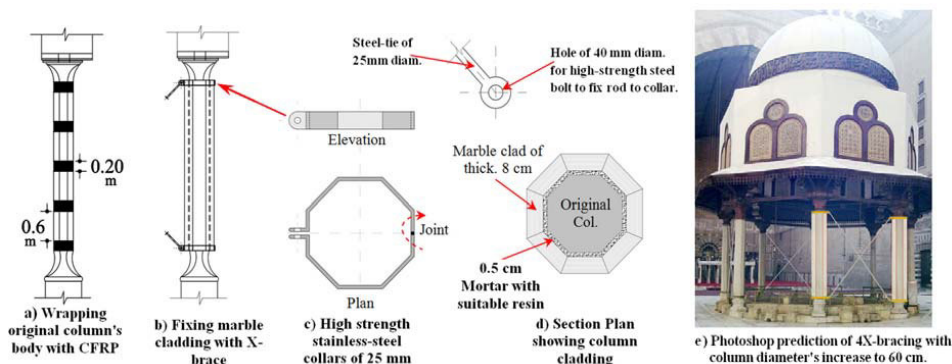

Fig. 12: Detailing and prediction figures of major retrofitting proposals.

8. Conclusions and Recommendations

The present research studies the structural stability and seismic retrofitting of central roofed fountains in historical medieval buildings in Cairo, to enhance its strength and reduce its lateral drift under seismic loads, which are the major cause of deficiencies of these structures. The central fountain of 'Sultan Hassan' madrasa in Cairo was considered in the study since its architecture represents a good example of its counterparts.

The following conclusions can be derived:

- Seismic actions are the major cause of deficiencies, damages and destructions in historical buildings in Cairo, since Egypt has encountered frequent moderate to strong earthquakes throughout time, as proved by historic documents. Two strong earthquakes were reported in the years 1847 and 1870, which caused severe structural damages and deficiencies in all historical structures in Cairo.
- Historical roofed fountains in Cairo suffer from lack of bracing system, slender stone columns and high ductility due to light weight building materials (e.g. timber domes) that cause large and generally unsafe total lateral drifts and stresses in the fountain structure under seismic loads. This would cause partial and sometimes total failure of the structure. Otherwise, they can merely cause severe damages to collateral brittle building materials, such as cladding and partitions.
- Structural analysis work of the current condition of the "Sultan Hassan" fountain showed that it is structurally safe under static loads only, while it is highly vulnerable to seismic loads. Also, marble columns are susceptible to buckling due to their high slenderness ratio. Eigen-value analysis of the current structural condition of the fountain showed high modal participating periods. Linear response-spectrum analysis resulted in high total lateral drift value and high tensile stresses at the columns' top section, which are both unsafe. Hence, all marble columns are found to be the most vulnerable of the fountain's structural elements under seismic actions.
- All retrofitting proposals would comprise the installation of stainless-steel collar over each lead joint between the column's body and its stone base and head. These collars can restrain relative sliding at the column's lead joints, limit the column's amplitude of oscillations, and they are able to reduce the risk of the fountain's columns to overturn and rock. Each steel collar will be concealed by covering it with aesthetic brass ring.
- The first retrofitting proposal recommends increasing the columns' diameter to be 0.7 m. Analysis shows this proposal merely increases the columns' safety against both buckling and stresses under seismic loads, while it leaves the high lateral drift problem unsolved.
- The second retrofitting proposal examines the installation of mutual '4' x-bracing system among the columns' bays without conducting any restoration work to the fountain's elements. The third proposal examines the installation of '8' x-bracing system. These two proposals considerably reduce the total drift and satisfy the reversibility as they can be dismantled in the future. However, lateral drift, and the columns' buckling criteria and tensile stresses at the columns' top joints are still unsafe. This proves that the installation of x-bracing system only (even by shoring) can cause severe damages to the fountain's columns. The '8' x-bracing system provides better structural results towards safety, although the '4' x-bracing system is more economic and better viewed.

- The researcher repeated the last two proposals, but substituted each of them with relevant v-shape instead of x-shape. The preliminary dynamic analysis of the fountain shows that both x-bracing and v-bracing systems provide very similar results of eigen modal periods, total lateral drift and stress values at the columns' top end sections under eigen modal and response spectrum load cases respectively. Preference is given to x-shape, since welding tie-bars at intersection points would shorten its unsupported length compared to v-bracing case.
- The final two proposals examine the combination of x-bracing system, either '4' or '8', with the increase of the columns' diameter to be 0.6 m. Both would overcome all structural risks. These proposals show great enhancement in column buckling, lateral drift and seismic stability. The best result is obtained in model-8, since all stresses and lateral drift is safe.

Recommendations of the Present Research are as Follows:

- Leaving the fountain in its current state can be very risky in case of any strong earthquake, such as the one that occurred in Egypt during the 18th Century. Hence, structural retrofitting of the fountain against seismic actions can be considered an obligatory issue.
- If temporary solution is implemented by the authorities, such as shoring at the open bays of the fountain using x-shape or merely installing the proposed x-bracing retrofitting, the upper lead joints of all marble columns should be wrapped with proper FRP laminates system and covered by steel collars with brass overlay.
- The researcher highly recommends to rapidly installing in the fountain the mutual '4' x-bracing system by increasing the columns' diameter to be 0.6 m (model-7). This provides nearly the same results of the best proposal (model-8). Moreover, it is rather reversible, more economic, and the four open bays will help to show the original view of the fountain.
- Every lead joint between the marble column's body and its head and base should be wrapped by CFRP strips of 4 cm wide and with proper overlap and rounds. Then, the joint should be confined by a stainless-steel collar that is concealed by aesthetic brass ring.
- Advanced seismic monitoring and structural analysis should be conducted in the near future. They would provide more information about the fountain of 'Sultan Hassan' madrasa, which can help to reach more reliable and safer structural retrofitting and conservation work with less visibility disturbance.
- Installing essential structural conservation and retrofitting work into historical buildings with minimum visibility should be allowed by the Egyptian authorities. The authorities should consider the structural safety and stability in the conservation of historical structures than compliance with full conservation criteria.

Works Cited

- Abdel-Aty, Yaser. *Analysis and Assessment of Structural Deficiencies in Historical Islamic Religious Buildings from Bahri Mamluk Period and the Possible Scientific Methods for Conservation and Restoration with Application on the Madrasa of Umm Al-Sultan Sha'ban in Cairo*. 2004. Cairo University, Unpublished Ph.D. thesis.
- Abdel-Wahab, Hassan. *Tareekh Al-Masajid Al-Athariyah fe al-Qahira Part II*. Al-Nahda Al-Masryeh Publisher, 1946.
- Abouseif, Doris. *Islamic Architecture in Cairo*. The American University in Cairo Publisher, 1989.
- Alinari, F. "Fountain of Sultan Hassan". *Gettyimages*, N-539582502, 1900, <http://media.gettyimages.com/photos/the-fountain-of-ablution-in-the-mosque-of-the-sultan-hassan-in-cairo-picture-id539582502?s=594x594>.
- Al-Maqrizi. *Al-Khitat al-Tawfiqiya*, 1st Ed., Part II. Madbouli Bookshop Publisher, 1997.
- Badawy, Ahmed. "Historical Seismicity of Egypt". *Acta Geodaetica et Geophysica Hungarica*, vol. 34, no. 1-2, 1999, pp. 119-135.
- Bedford, Francis. "Fountain of Sultan Hassan". *Getty*, N-22571601, 1862, <http://www.getty.edu/museum/media/images/web/download/22571601.jpg>.
- Cadoni, Ezio, et al. "Mechanical Characterization of Rocks at High Strain Rate." *EPJ Web of Conferences*, 26, 01021, 2012, p. 2, <http://www.epj-conferences.org>.
- Ciccu, Raimondo, et al. "Strategic Study on the Egyptian Marble and Granite Sector." *Industrial Modernisation Programme*. STEM-VCR Srl Publisher, 2005, pp. 75-87, <http://www.imc-egypt.org/studies/FullReport/>.
- *Comite' de conservation des monument de l'art Arabe*. Egyptian ministry of Antiquities Pub., Group No. 23, 1905.
- *CSi Analysis Reference Manual for SAP2000*. SAP2000 ver.16, Linear and Nonlinear Structural Analysis Software, e-book, Computers and Structures Inc. Publisher, 2013.
- *ECP-201. Egyptian Code of Practice for Calculating Loads in Structural and Masonry Works*. Ministry of Housing, Public Utilities and Building Development, Code No. 201, Cairo, 2008 (in Arabic).
- *ECP-204. Egyptian Code of Practice for Design and Execution of Masonry Buildings*. Ministry of Housing, Public Utilities and Building Development, Code No. 204, Cairo, 2005 (in Arabic).
- El-Basha, Hassan, et al. *Al-Qahira: History, Arts and Monuments*. Al-Ahram

Publisher, 1970.

- Griffis, Lawrence. "Serviceability Limit States under Wind Load". *Engineering Journal*, American Institute of Steel Construction, 1st Quarter, 1993, <http://ef.engr.utk.edu/ce576-2016-01/hw/Serviceability-Limit-States.pdf>.
- Herz, Max. *La Mosquée du Sultan Hassan au Caire*, Plates XIII to XI, Lajnat Hifz al-Āthār al-Arabīyah in Egypt Publisher, 1899, <http://archive.org/details/mosqueedusultanHassanauCaire00leca>.
- Ibrahim, Abdel-Baqi, et al. *Principles of Architectural Design and Urban Planning during Different Islamic Eras*. Organization of Islamic Capitals and Cities Publisher, 1990, pp. 451-456.
- *IS-1893. Indian Standard Criteria for Earthquake Resistant Design of Structures*. General Provisions and Buildings, 5th Revision, Part 1, close 7.11, 2002, p.27.
- István, Ormos. *Max Herz Pasha on Arab-Islamic Art in Egypt*. Collections électroniques de l'INHA, Institut national d'histoire de l'art Pub., e-book, <http://inha.revues.org/4898>.
- Mahir, Mostafa et al. "Study of Structural Deficiencies and Damages in Timber Roofs at Islamic Historic Buildings in Cairo, Their Causes and Methodology for Restoration and Retrofitting: Applying to Ghanim al-Bahlawan Mosque in Cairo", *the 4th International Conference of Restoration of Minia University*, Faculty of Fine Arts, Minia Governorate, Egypt, 2015, pp. 37-43.
- Mahir, So'aad. *Masajid Misr wa Awleya'ha al-Salehoon*, Part IV. Supreme Council of Islamic Affairs, Al-Ahram Publisher, 1971.
- Marinella, Fossetti, et al. "Effect of Steel Collars on the Seismic Behaviour of Axially Cracked Historical Stone Columns", *Engineering Structures*, vol. 59, 2014, pp. 344–354, <https://www.researchgate.net/publication/259509179>.
- Mubark, Ali, *Al-Khitat al-Jadida le-Misr*, Part IV. Bolaq Publisher, 1888, pp. 80-87.
- Waly, Tarek. *Madrasa of Sultan Hassan*. Tarek Waly Center, 1996, <http://www.walycenter.org/en/research/publications/books/139-madrasa-al-sultan-hassan>.
- Waziri, Yehya. *Mawso'at al-'Emaara al-Islamia*, Part-III. Madbouli Library Publisher, 1999.
- *Wood Handbook, Wood as an Engineering Material*, Centennial Edition, e-book, Forest Products Laboratory, United States Department of Agriculture Forest Service, Madison, Wisconsin, 2010, p. 5-7. www.fpl.fs.fed.us.
- Yeomans, Richard. *The Art and Architecture of Islamic Cairo*. Garnet Publishing LimitedS, 2006.